



US 20110080395A1

(19) **United States**

(12) **Patent Application Publication**
Chung

(10) **Pub. No.: US 2011/0080395 A1**

(43) **Pub. Date: Apr. 7, 2011**

(54) **PIXEL CIRCUIT, ORGANIC ELECTRO-LUMINESCENT DISPLAY APPARATUS USING THE PIXEL CIRCUIT AND METHOD OF DRIVING THE APPARATUS**

Publication Classification

(51) **Int. Cl.**
G09G 3/30 (2006.01)
G06F 3/038 (2006.01)

(52) **U.S. Cl.** **345/211; 345/76**

(76) **Inventor: Kyung-Hoon Chung, Yongin-city (KR)**

(57) **ABSTRACT**

(21) **Appl. No.: 12/766,387**

An organic electro-luminescent display apparatus including a pixel circuit and a method of driving the organic electro-luminescent display apparatus are provided. Embodiments of the present invention may solve problems where the luminance of light is changed due to a change of a voltage of an anode of an organic electro-light emitting device such that an image quality is deteriorated when N-type transistors are used to form the organic electro-luminescent display apparatus.

(22) **Filed: Apr. 23, 2010**

(30) **Foreign Application Priority Data**

Oct. 7, 2009 (KR) 10-2009-0095172

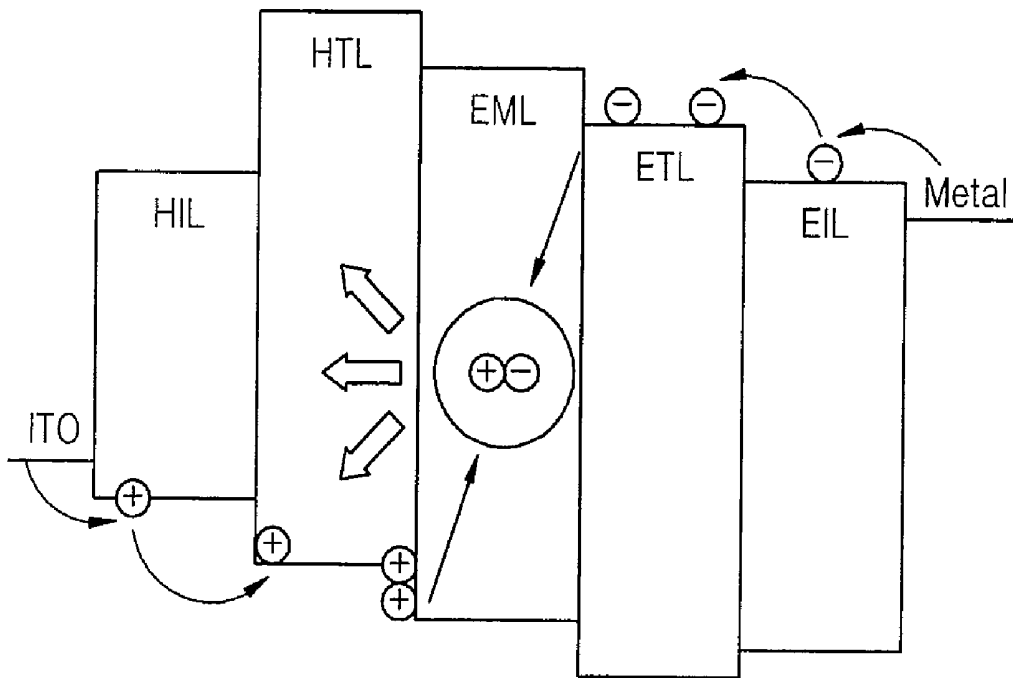

FIG. 1

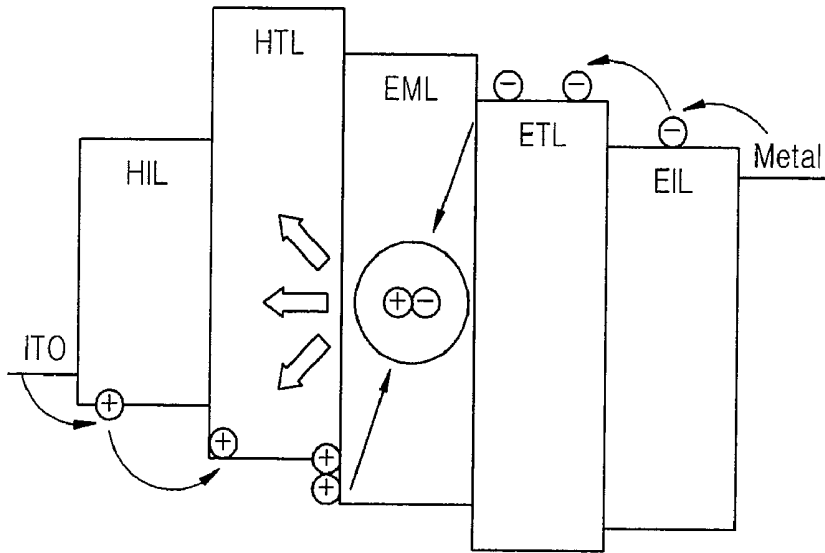

FIG. 2

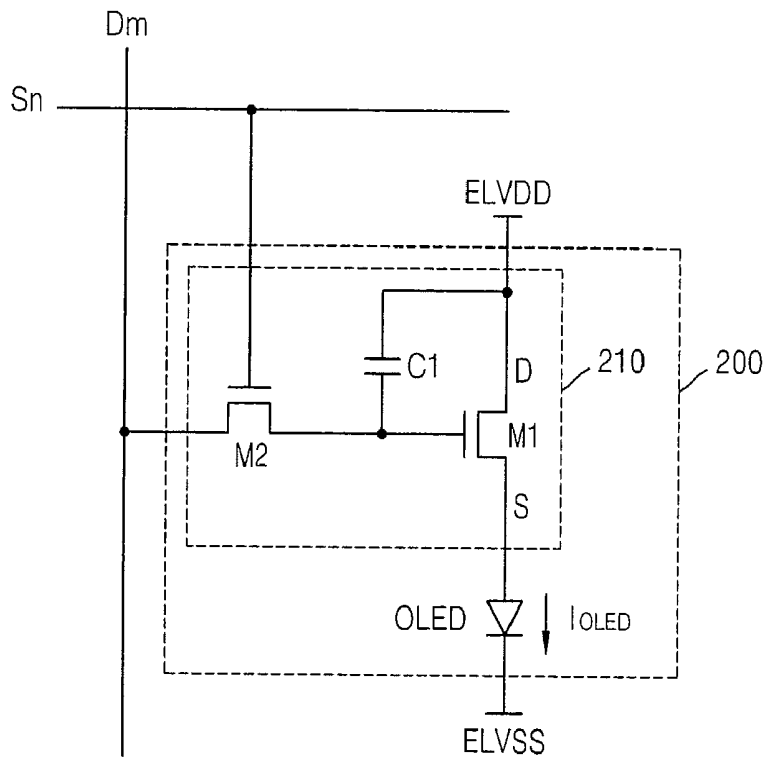

FIG. 3

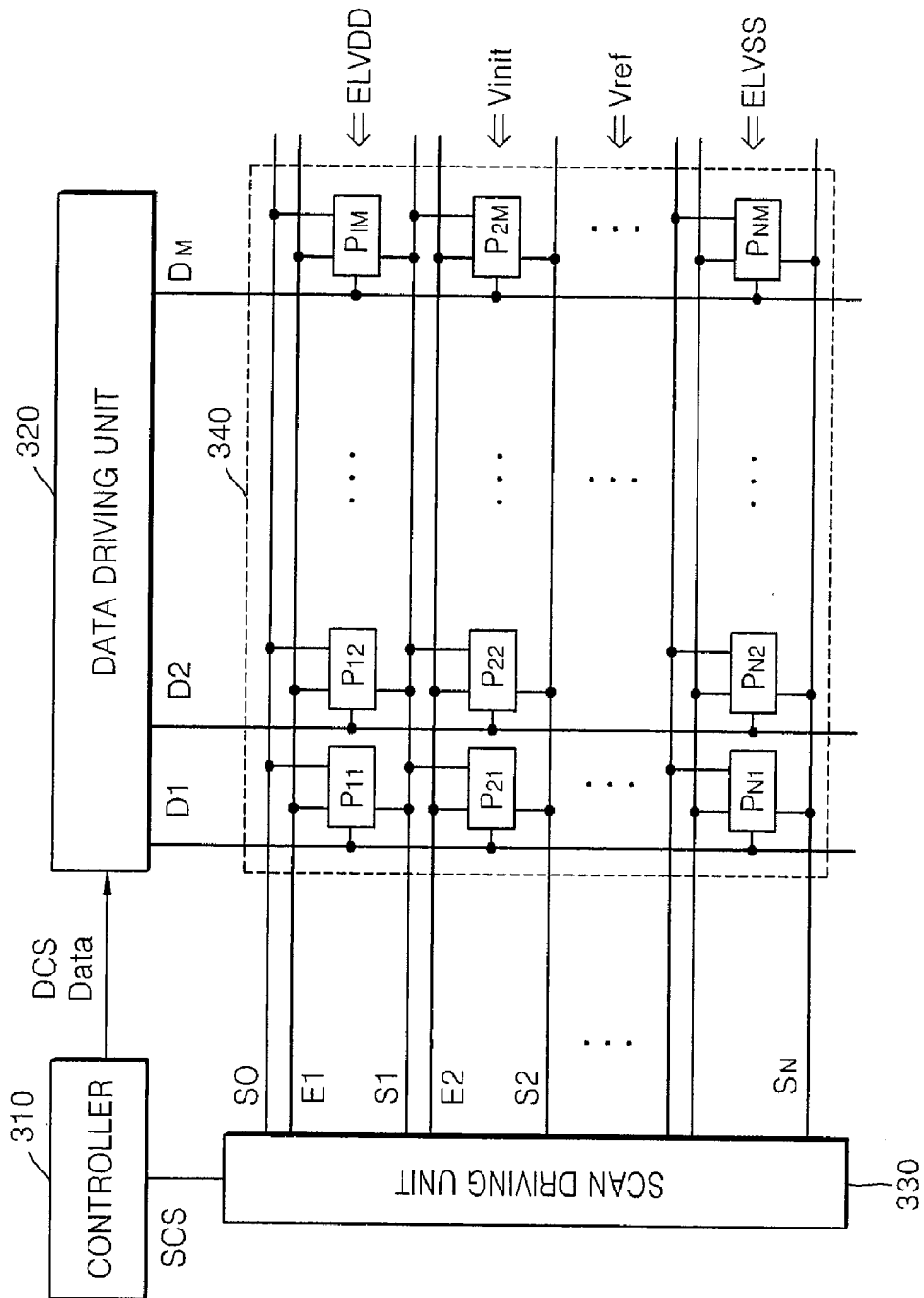

FIG. 4

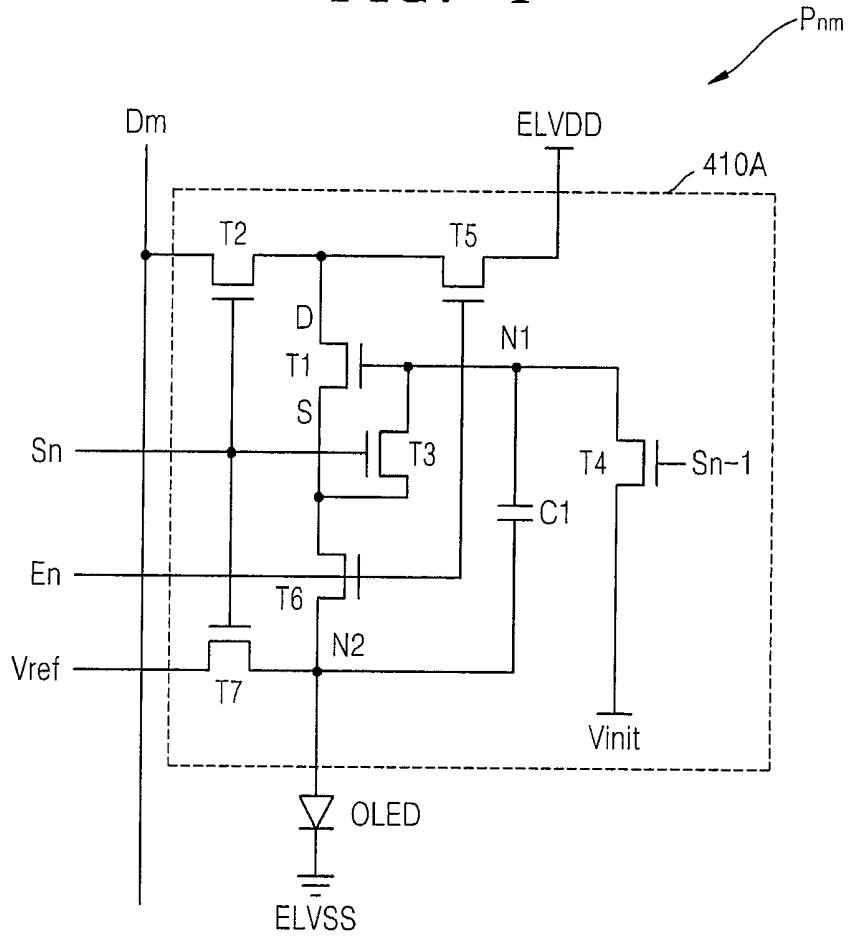

FIG. 5

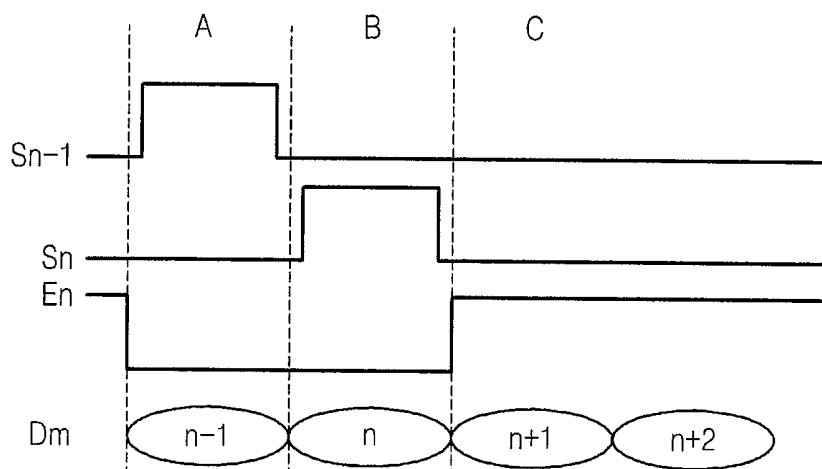

FIG. 6A

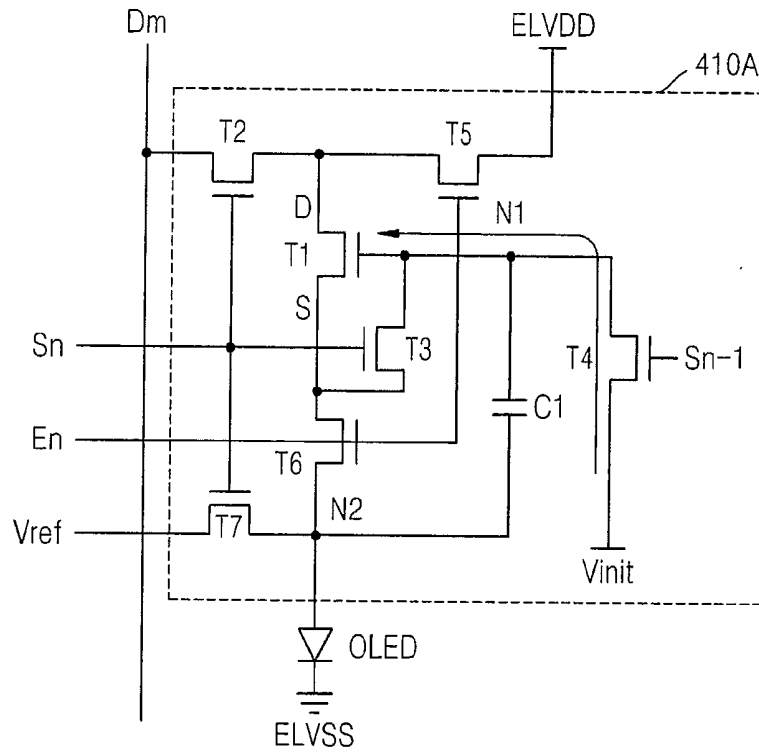

FIG. 6B

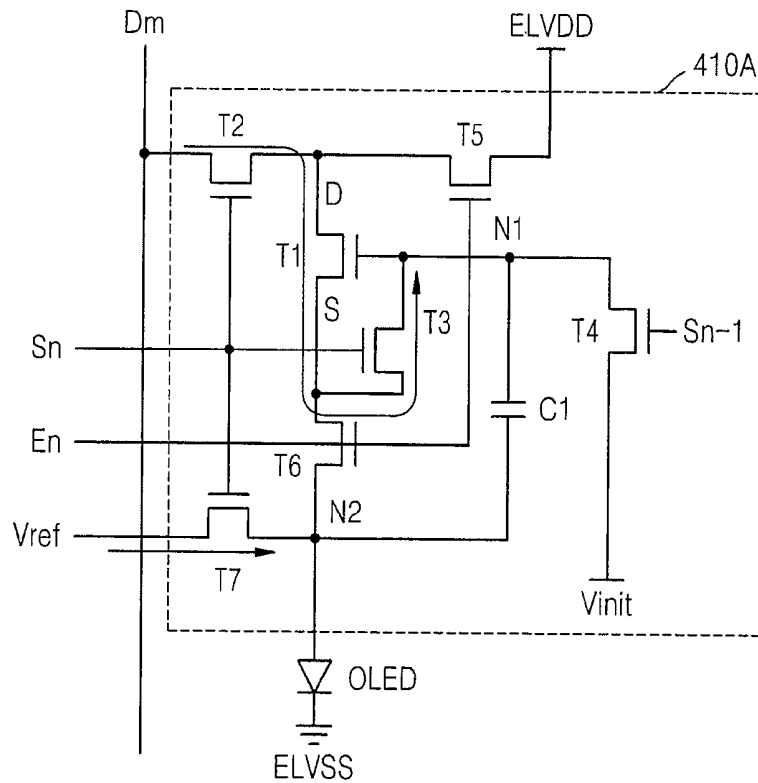

FIG. 6C

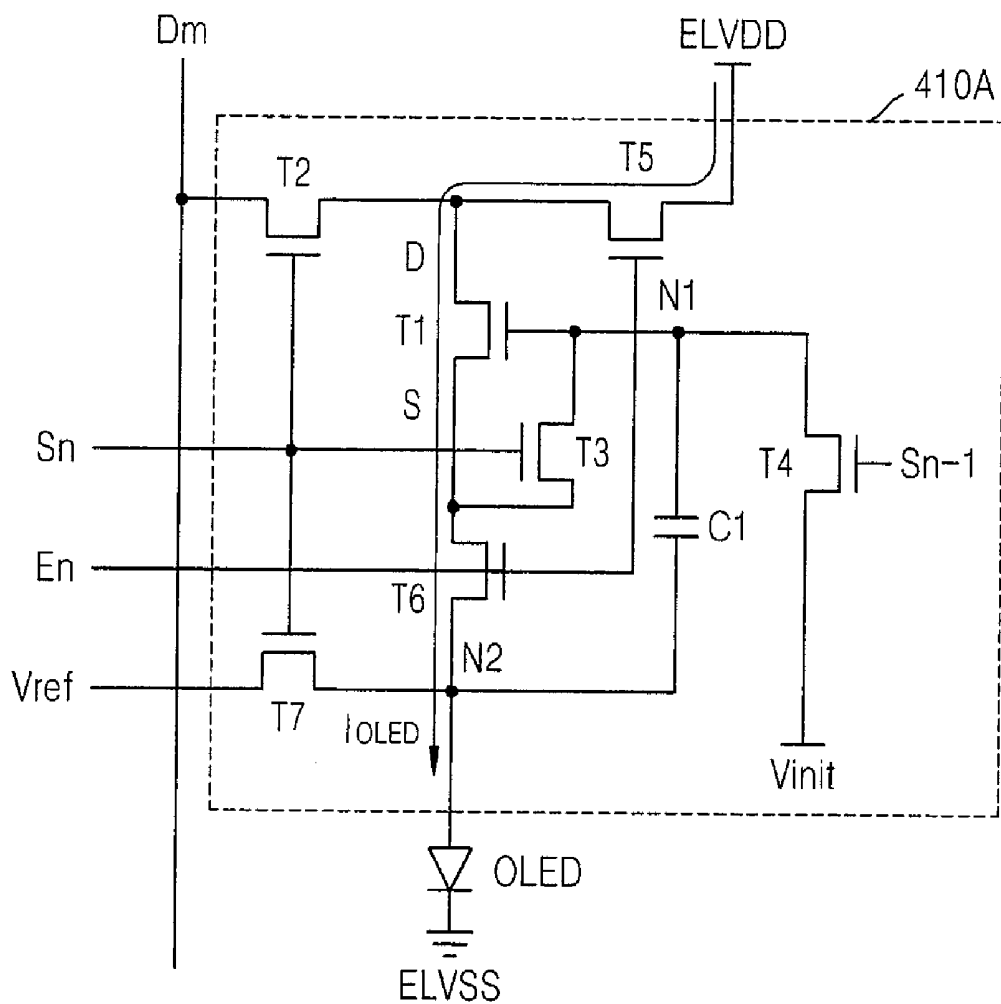

FIG. 7

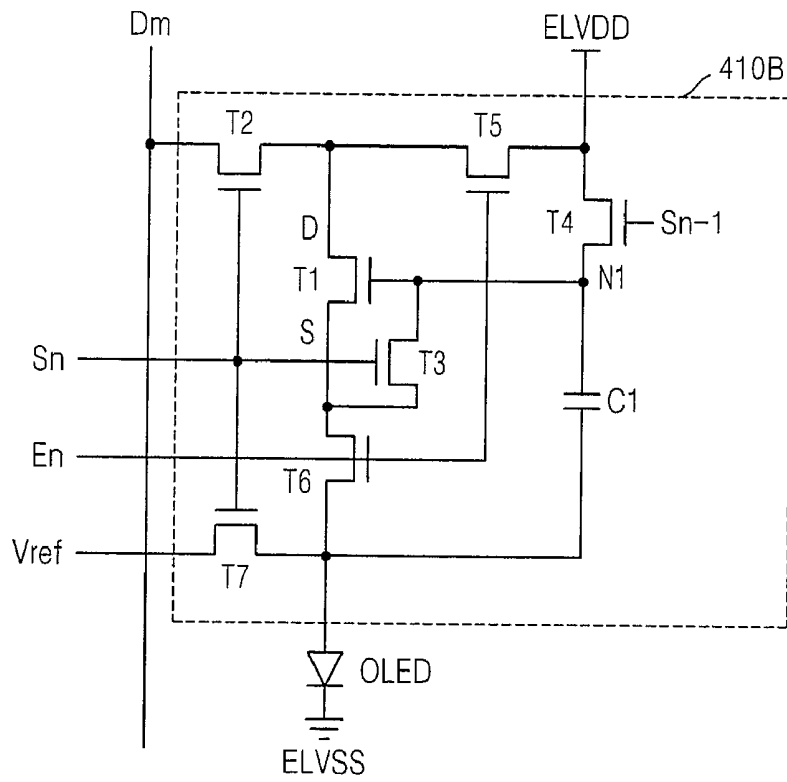

FIG. 8

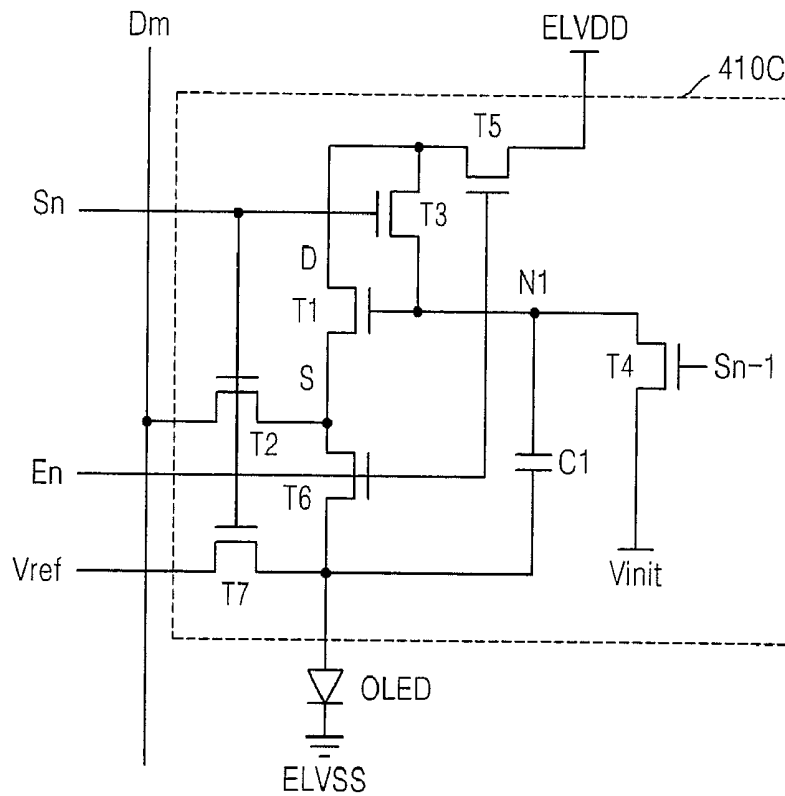

FIG. 9

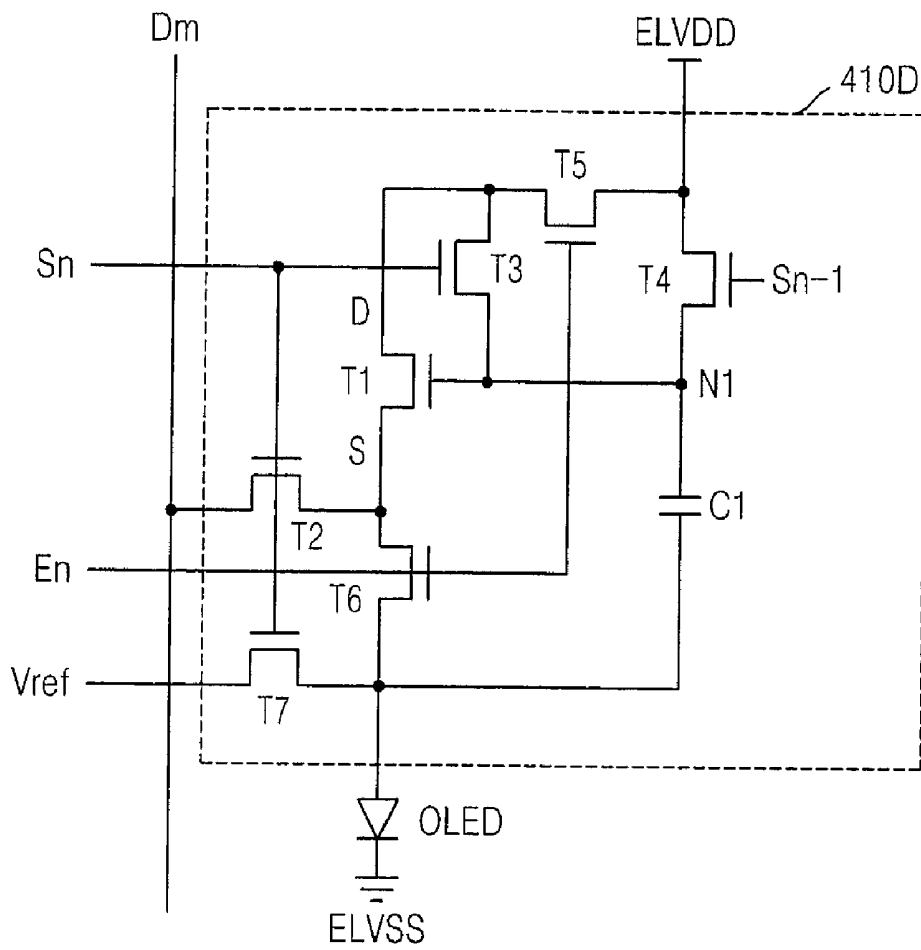
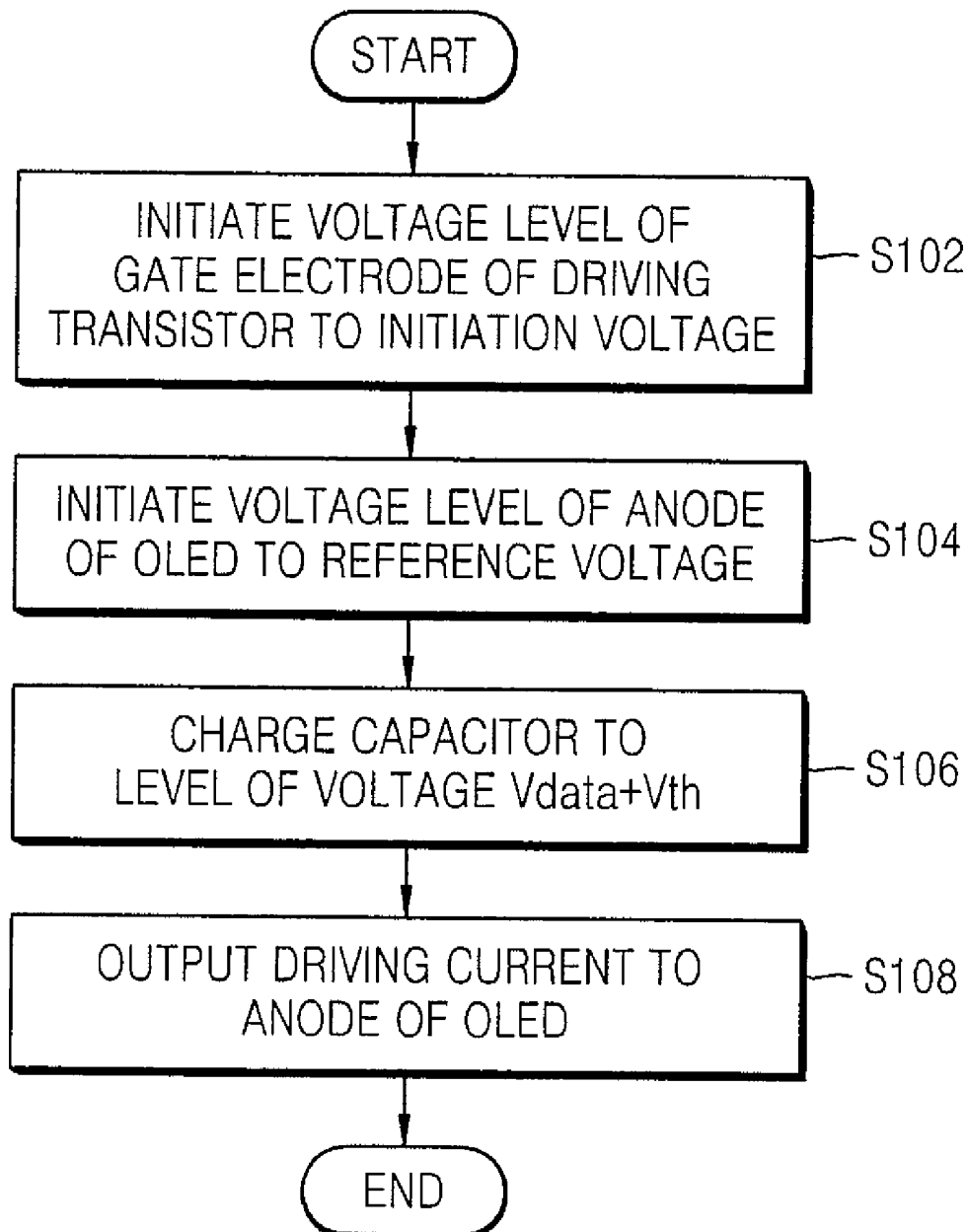

FIG. 10



**PIXEL CIRCUIT, ORGANIC
ELECTRO-LUMINESCENT DISPLAY
APPARATUS USING THE PIXEL CIRCUIT
AND METHOD OF DRIVING THE
APPARATUS**

CROSS-REFERENCE TO RELATED
APPLICATIONS

[0001] This application claims priority to and the benefit of Korean Patent Application No. 10-2009-0095172, filed on Oct. 7, 2009, in the Korean Intellectual Property Office, the disclosure of which is incorporated herein in its entirety by reference.

BACKGROUND

[0002] 1. Field

[0003] Aspects of one or more embodiments of the present invention relate to a pixel circuit, an organic electroluminescent display apparatus using the pixel circuit, and a method of driving the organic electroluminescent display apparatus.

[0004] 2. Description of the Related Art

[0005] Display apparatuses apply a data driving signal, which corresponds to input data, to a plurality of pixel circuits so as to control the luminance of each of the pixels and to convert the input data into an image that is provided to a viewer. The data driving signal to be output to the plurality of pixel circuits is generated from a data driving unit. The data driving unit selects a gamma voltage, which corresponds to the input data, from among a plurality of gamma voltages generated from a gamma filter circuit unit, and outputs the selected gamma voltage as a data driving signal of the plurality of pixel circuits.

SUMMARY

[0006] One or more embodiments of the present invention provide a pixel circuit of an organic electroluminescent display apparatus including the pixel circuit and a method of driving the organic electroluminescent display apparatus which may solve problems where the luminance of light is changed due to a change of a voltage level of an anode of an organic electro-light emitting device such that image quality is deteriorated, when N-type transistors are used to form the organic electroluminescent display apparatus.

[0007] According to an embodiment of the present invention, there is provided a pixel circuit for driving a light emitting device including a first electrode and a second electrode, the pixel circuit including: a driving transistor including a first electrode and a second electrode for outputting a driving current according to a voltage applied to a gate electrode of the driving transistor; a second transistor for delivering a data signal to the gate electrode of the driving transistor in response to a scan control signal applied to a gate electrode of the second transistor; a third transistor for diode-connecting the driving transistor in response to the scan control signal applied to a gate electrode of the third transistor; a fourth transistor for applying an initialization voltage to the gate electrode of the driving transistor in response to an initialization control signal; a fifth transistor for applying a first power voltage to the second electrode of the driving transistor in response to an emission control signal; a sixth transistor coupled in series between the first electrode of the driving transistor and the first electrode of the light emitting device for outputting the driving current output from the driving

transistor to the first electrode of the light emitting device in response to the emission control signal applied to a gate electrode of the sixth transistor; a seventh transistor for applying a reference voltage to the first electrode of the light emitting device in response to the scan control signal; and a capacitor including a first electrode and a second electrode, wherein the first electrode is coupled to the gate electrode of the driving transistor and the second electrode is coupled to the first electrode of the light emitting device, wherein the pixel circuit is configured such that the data signal is delivered to the gate electrode of the driving transistor through the second transistor, the driving transistor, and the third transistor, and wherein the driving transistor and the second, third, fourth, fifth, sixth, and seventh transistors are N-type transistors. The light emitting device may include an organic light-emitting diode.

[0008] The second transistor may include a first electrode for receiving the data signal and a second electrode coupled to the second electrode of the driving transistor, and the third transistor may include a first electrode coupled to the gate electrode of the driving transistor and a second electrode coupled to the first electrode of the driving transistor.

[0009] The initialization voltage may be substantially the same as the first power voltage.

[0010] The second transistor may include a first electrode coupled to the data signal and a second electrode coupled to the first electrode of the driving transistor, and the third transistor may include a first electrode coupled to the gate electrode of the driving transistor and a second electrode coupled to the second electrode of the driving transistor. The initialization voltage may be the first power voltage.

[0011] The second electrode of the light emitting device may be configured to receive a second power voltage, and the reference voltage may be lower than a sum of the second power voltage and a threshold voltage of the light emitting device. Accordingly, the reference voltage is set to a voltage level at which the light emitting device is not emitted.

[0012] The initialization control signal may be a scan control signal of a previous scan period. Also, the driving transistor and the second, third, fourth, fifth, sixth, and seventh transistors may be N-type metal-oxide semiconductor field effect transistors.

[0013] The first electrode of the driving transistor may be a source electrode, and the second electrode of the driving transistor may be a drain electrode.

[0014] The pixel circuit may be configured such that: during a first time duration, when the initialization control signal may be at a first level, the scan control signal and the emission control signal may be at a second level; during a second time duration, when the data signal has a valid level, the initialization control signal and the emission control signal may be at the second level, and the scan control signal may be at the first level; and during a third time duration, when the initialization control signal and the scan control signal may be at the second level, the emission control signal may be at the first level, and wherein the first level may be a level at which the driving transistor and the second, third, fourth, fifth, sixth, and seventh transistors are turned on, and the second level may be a level at which the driving transistor and the second, third, fourth, fifth, sixth, and seventh transistors are turned off.

[0015] According to another embodiment of the present invention, there is provided an organic electroluminescent display apparatus including: a pixel array including a plurality of pixels; a scan driver configured to output an initializa-

tion control signal, a scan control signal, and an emission control signal to the plurality of pixels; and a data driver configured to generate a data signal and output the data signal to the plurality of pixels, wherein each of the plurality of pixels includes: an organic light-emitting diode (OLED) including a first electrode and a second electrode; a driving transistor including a first electrode and a second electrode for outputting a driving current according to a voltage applied to a gate electrode of the driving transistor; a second transistor for delivering a data signal to the gate electrode of the driving transistor in response to a scan control signal applied to a gate electrode of the second transistor; a third transistor for diode-connecting the driving transistor in response to the scan control signal applied to a gate electrode of the third transistor; a fourth transistor for applying an initialization voltage to the gate electrode of the driving transistor in response to an initialization control signal; a fifth transistor for applying a first power voltage to the second electrode of the driving transistor in response to an emission control signal; a sixth transistor coupled in series between the first electrode of the driving transistor and the first electrode of the OLED for outputting the driving current output from the driving transistor to the first electrode of the OLED in response to the emission control signal applied to a gate electrode of the sixth transistor; a seventh transistor for applying a reference voltage to the first electrode of the OLED in response to the scan control signal; and a capacitor including a first electrode and a second electrode, wherein the first electrode is coupled to the gate electrode of the driving transistor and the second electrode is coupled to the first electrode of the OLED, wherein the second transistor is configured to deliver the data signal to the gate electrode of the driving transistor through the second transistor, the driving transistor, and the third transistor, and wherein the driving transistor and the second, third, fourth, fifth, sixth, and seventh transistors are N-type transistors.

[0016] According to another embodiment of the present invention, there is provided a method of driving an organic electroluminescent display apparatus including a pixel array including a plurality of pixels, wherein each of the plurality of pixels includes an organic light-emitting diode (OLED) and a pixel circuit including N-type transistors and a capacitor coupled between a gate electrode of a driving transistor and an anode of the OLED, the method including: initializing the gate electrode of the driving transistor to an initialization voltage; initializing the anode of the OLED to a reference voltage; charging the capacitor to a voltage level corresponding to a sum of a threshold voltage of the driving transistor and a data signal by diode-connecting the driving transistor and applying the data signal to the gate electrode of the driving transistor; and outputting a driving current from the driving transistor to the anode of the OLED according to the voltage level charged to the capacitor.

BRIEF DESCRIPTION OF THE DRAWINGS

[0017] The above and other features and aspects of the present invention will become more apparent by describing in detail exemplary embodiments thereof with reference to the attached drawings in which:

[0018] FIG. 1 is a diagram for explaining a luminescence principle of an organic electro-light emitting device;

[0019] FIG. 2 is a diagram of a pixel circuit including N-type transistors;

[0020] FIG. 3 is a diagram of an organic electroluminescent display apparatus according to an embodiment of the present invention;

[0021] FIG. 4 is a diagram of a pixel circuit according to an embodiment of the present invention;

[0022] FIG. 5 is a timing diagram of driving signals, according to an embodiment of the present invention;

[0023] FIG. 6A is a diagram for illustrating an operation of a pixel circuit in a first time duration A;

[0024] FIG. 6B is a diagram for illustrating an operation of a pixel circuit in a second time duration B;

[0025] FIG. 6C is a diagram for illustrating an operation of a pixel circuit in a third time duration C;

[0026] FIG. 7 is a diagram of a pixel circuit according to another embodiment of the present invention;

[0027] FIG. 8 is a diagram of a pixel circuit according to another embodiment of the present invention;

[0028] FIG. 9 is a diagram of a pixel circuit according to another embodiment of the present invention; and

[0029] FIG. 10 is a flowchart for illustrating a method of driving an organic electroluminescent display apparatus, according to an embodiment of the present invention.

DETAILED DESCRIPTION

[0030] Hereinafter, embodiments of the present invention will be described more fully with reference to the accompanying drawings. The detailed description and the drawings are provided for understanding aspects of the present invention, and the detailed descriptions of well-known technologies may be omitted. In addition, the specification and the drawings are not provided to limit the scope of the present invention. The terms and terminologies used herein are for the purpose of describing exemplary embodiments.

[0031] Unless specified otherwise, transistors described in the specification are N-type transistors, and may be, for example, N-type metal oxide semiconductor field effect transistors (MOSFETs) according to one embodiment.

[0032] FIG. 1 is a diagram for illustrating a luminescence principle of an organic electro-light emitting device.

[0033] An organic electroluminescent display apparatus electrically excites fluorescent organic compounds to emit light. In the organic electroluminescent display apparatus, organic electro-light emitting devices arranged in a matrix are voltage- or current-driven so as to display an image. The organic electro-light emitting devices have characteristics of a diode and thus are called organic light emitting diodes (OLEDs).

[0034] An OLED has a structure in which an anode (e.g., indium tin oxide (ITO)), an organic thin film, and a cathode (e.g., metal) are stacked together. In order to balance electrons and holes and thus improve luminance efficiency, the organic thin film includes an emitting layer (EML), an electron transport layer (ETL), and a hole transport layer (HTL). The organic thin film may further include a hole injection layer (HIL) or an electron injection layer (EIL).

[0035] A process for forming an amorphous silicon (a-Si) transistor may be performed with lower cost than a process for forming a poly-Si transistor. However, according to a characteristic of the a-Si transistor, typically, only N-type metal oxide semiconductor transistors may be used to form a pixel circuit. Also, according to a characteristic of an oxide thin-film transistor (TFT), typically, only N-type transistors may be used to form a pixel circuit.

[0036] FIG. 2 is a diagram of a pixel circuit 210 including N-type transistors.

[0037] An organic electroluminescent display apparatus includes a plurality of pixels 200 each including an OLED and the pixel circuit 210. The OLED receives driving current I_{OLED} that is output from the pixel circuit 210 and emits light. The luminance of light emitted from the OLED varies according to amplitude of the driving current I_{OLED} .

[0038] In one embodiment, the pixel circuit 210 includes a capacitor C1, a driving transistor M1, and a second transistor M2.

[0039] When a scan control signal S_n is applied to a gate electrode of the second transistor M2, a data signal D_m is applied to a gate electrode of the driving transistor M1 and a first electrode of the capacitor C1 through the second transistor M2. While the data signal D_m is applied, a voltage level corresponding to that of the data signal D_m is charged between the terminals of the capacitor C1. According to the level of the data signal D_m , the driving transistor M1 generates the driving current I_{OLED} and outputs the generated driving current I_{OLED} to an anode of the OLED.

[0040] The OLED receives the driving current I_{OLED} from the pixel circuit 210 and emits light having luminance corresponding to the data signal D_m .

[0041] The driving current I_{OLED} output from the driving transistor M1 is determined according to Equation 1.

$$I_{OLED} = k(V_{gs} - V_{th})^2 \quad \text{Equation 1}$$

[0042] Here, k is a constant, V_{gs} is a voltage between the gate electrode and a source electrode of the driving transistor M1, and V_{th} is a threshold voltage of the driving transistor M1. When a pixel circuit is formed by N-type transistors, a voltage level of the source electrode of the driving transistor M1 is determined by a voltage level of the anode of the OLED.

[0043] V_{gs} of the driving transistor M1 in the pixel circuit illustrated in FIG. 2 is given by Equation 2.

$$V_{gs} = V_{data} - (ELVSS + V_{OLED}) \quad \text{Equation 2}$$

[0044] Here, V_{data} is a voltage level of the data signal D_m , and V_{OLED} is a voltage between the electrodes of the OLED. As illustrated in Equation 2, V_{gs} of the driving transistor M1 is affected by a cathode power voltage ELVSS and V_{OLED} . In the case of a large-sized display apparatus, the value of V_{gs} varies due to an IR voltage drop by a parasitic resistance component of a wiring, which delivers the cathode power voltage ELVSS, and a voltage drop due to a current flowing into each pixel while the cathode power voltage ELVSS is delivered to each pixel. In addition, V_{OLED} changes while the pixel is driven, and V_{OLED} changes according to a change of a threshold voltage of the OLED due to degradation of the OLED.

[0045] When a voltage level of the gate electrode of the driving transistor M1 increases, the driving current I_{OLED} increases and thereby the voltage V_{OLED} applied between the terminals of the OLED increases. However, when the voltage V_{OLED} increases, a voltage of the source electrode of the driving transistor M1 increases and thereby V_{gs} decreases, as illustrated in Equation 2. Accordingly, in order to generate light having desired luminance, the data voltage V_{data} should increase in the above described example.

[0046] In the pixel circuit formed by N-type transistors, a voltage of the source electrode of the driving transistor M1 is unstable (e.g., varies) so that a luminance of a displayed image is changed and quality thereof is deteriorated.

[0047] According to embodiments of the present invention, a pixel circuit formed with N-type transistors may resolve the above described problems. Transistors included in pixel circuits, according to embodiments of the present invention that are described below, are N-type transistors.

[0048] FIG. 3 is a diagram of an organic electroluminescent display apparatus according to an embodiment of the present invention.

[0049] The organic electroluminescent display apparatus according to one embodiment includes a controller 310, a data driving unit 320 (e.g., a data driver), a scan driving unit 330 (e.g., a scan driver), and a pixel array 340.

[0050] The controller 310 generates RGB data and a data driving unit control signal DCS and outputs the generated RGB data and data driving unit control signal DCS to the data driving unit 320. Also, the controller 310 generates a scan driving unit control signal SCS and outputs the generated scan driving unit control signal SCS to the scan driving unit 330.

[0051] The data driving unit 320 generates the data signals $D_1 \dots D_m$ from the RGB data and outputs the generated data signals $D_1 \dots D_m$ to pixels $P_{11} \dots P_{NM}$ of the pixel array 340, where N and M are natural numbers. The data driving unit 320 may generate the data signals $D_1 \dots D_m$ from the RGB data by using a gamma filter and a digital-to-analog conversion circuit. During a single scanning period, each of the data signals $D_1 \dots D_m$ may be concurrently output to pixels $P_{11} \dots P_{NM}$ of the pixel array 340 located at the same row. In addition, each of a plurality of data lines which delivers the data signals $D_1 \dots D_m$ may be commonly connected to the pixels $P_{11} \dots P_{NM}$ of the pixel array 340 located at the same column.

[0052] The scan driving unit 330 generates scan control signals $S_0 \dots S_n$ and emission control signals $E_0 \dots E_n$ from the scan driving unit control signal SCS and outputs the generated scan control signals $S_0 \dots S_n$ and emission control signals $E_0 \dots E_n$ to the pixels $P_{11} \dots P_{NM}$ of the pixel array 340. Each of a plurality of scan control signal lines which deliver the scan control signals $S_0 \dots S_n$ and each of a plurality of emission control signal lines which deliver the emission control signals $E_0 \dots E_n$ may be commonly connected to the pixels $P_{11} \dots P_{NM}$ of the pixel array 340 located at the same row. The scan control signals $S_0 \dots S_n$ and the emission control signals $E_0 \dots E_n$ may sequentially drive each row.

[0053] The scan driving unit 330 according to one embodiment may further output initialization control signals in order to initiate a voltage of the gate electrode of the driving transistor of each of the pixels $P_{11} \dots P_{NM}$ of the pixel array 340. Each of the initialization control signals is output commonly to the pixels $P_{11} \dots P_{NM}$ of the pixel array 340 located at the same row and sequentially drives each row. Each of the initialization control signals is applied before a corresponding one of the scan control signals $S_0 \dots S_n$ is applied. According to one embodiment, the initialization control signal may be a scan control signal S_{n-1} of a previous row, as illustrated in FIG. 3. Accordingly, before a scan control signal S_1 for the first row is applied, the scan driving unit 330 may further output an additional scan control signal S_0 as an initialization control signal for the first row.

[0054] As illustrated in FIG. 3, the pixels $P_{11} \dots P_{NM}$ of the pixel array 340 may be arranged in an $N \times M$ matrix. The plurality of pixels $P_{11} \dots P_{NM}$ of the pixel array 340 may each include an OLED and a pixel circuit for driving the OLED. An

anode power voltage ELVDD, an initialization voltage Vinit, a reference voltage Vref, and the cathode power voltage ELVSS may be applied to each of the pixels $P_{11} \dots P_{NM}$ of the pixel array 340. According to one embodiment, the anode power voltage ELVDD may be used as the initialization voltage Vinit instead of applying the initialization voltage Vinit separately to each of the pixels $P_{11} \dots P_{NM}$. In one embodiment, the initialization voltage Vinit is not provided to the pixels $P_{11} \dots P_{NM}$ of the pixel array 340.

[0055] FIG. 4 is a diagram of a pixel circuit 410A according to an embodiment of the present invention.

[0056] A pixel Pnm located at the row n and the column m includes the pixel circuit 410A and an OLED. The pixel circuit 410A receives the data signal Dm from the data driving unit 320 through a data line and outputs the driving current I_{OLED} according to the data signal Dm to the OLED. The OLED emits light having luminance corresponding to the amplitude of the driving current I_{OLED} .

[0057] The pixel circuit 410A according to one embodiment includes a driving transistor T1, second, third, fourth, fifth, sixth, and seventh transistors T2, T3, T4, T5, T6, and T7, and a capacitor C1.

[0058] The third transistor T3 includes a first electrode connected to the gate electrode of the driving transistor T1, a second electrode connected to the source electrode of the driving transistor T1, and a gate electrode connected to the scan control signal Sn. The gate electrode and source electrode of the driving transistor T1 are electrically connected to each other through the third transistor T3. The third transistor T3 electrically connects the gate electrode of the driving transistor T1 and the source electrode of the driving transistor T1 in response to the scan control signal Sn and thus diode-connects the driving transistor T1. Here, "diode-connect" denotes that a gate electrode and a source electrode of a transistor or a gate electrode and a drain electrode are connected to each other so that the transistor acts as a diode.

[0059] The fifth transistor T5 includes a first electrode connected to the anode power voltage ELVDD, a second electrode connected to a drain electrode of the driving transistor T1, and a gate electrode connected to the emission control signal En. The sixth transistor T6 includes a first electrode connected to the source electrode of the driving transistor T1, a second electrode connected to an anode of the OLED, and a gate electrode connected to the emission control signal En. When the emission control signal En is applied at a first level (e.g., a logic-high signal), which may turn on the driving transistor T1 and the second through seventh transistors T2 through T7, the drain electrode of the driving transistor T1 is connected to the anode power voltage ELVDD through the fifth transistor T5, and the source electrode of the driving transistor T1 is connected to the anode of the OLED through the sixth transistor T6.

[0060] The second transistor T2 includes a first electrode connected to a data line, a second electrode connected to the drain electrode of the driving transistor T1, and a gate electrode connected to the scan control signal Sn.

[0061] The capacitor C1 includes a first electrode connected to the gate electrode of the driving transistor T1 and a second electrode connected to the anode of the OLED.

[0062] The fourth transistor T4 includes a first electrode connected to the gate electrode of the driving transistor T1, a second electrode connected to the initialization voltage Vinit, and a gate electrode connected to the initialization control signal (e.g., Sn-1). In one embodiment, when the initializa-

tion control signal Sn-1 is applied at a high level, the fourth transistor T4 applies the initialization voltage Vinit to the gate electrode of the driving transistor T1 and the first electrode of the capacitor C1.

[0063] The seventh transistor T7 includes a first electrode connected to the reference voltage Vref, a second electrode connected to the anode of the OLED, and a gate electrode connected to the scan control signal Sn. In one embodiment, when the scan control signal Sn is applied at a high level, the seventh transistor T7 applies the reference voltage Vref to the anode of the OLED.

[0064] FIG. 5 is a timing diagram of driving signals, according to an embodiment of the present invention.

[0065] Before a first time duration A, the driving current I_{OLED} according to the data signal Dm of a previous frame flows through the OLED as illustrated in FIG. 6C, and thus the OLED emits light.

[0066] During the first time duration A, the initialization control signal Sn-1 is at a first level (e.g., a logic high level), and the scan control signal Sn and the emission control signal En are at a second level (e.g., a logic low level). Here, the first level is the level when the driving transistor T1 and the second through seventh transistors T2 . . . T7 are turned on, and the second level is the level when the driving transistor T1 and the second through seventh transistors T2 . . . T7 are turned off.

[0067] FIG. 6A illustrates an operation of the pixel circuit 410A in the first time duration A.

[0068] During the first time duration A, the scan control signal Sn and the emission control signal En are at the second level, and thus the second transistor T2, the third transistor T3, and the fifth through seventh transistors T5 . . . T7 are turned off. The fourth transistor T4 is turned on in response to the initialization control signal Sn-1 at the first level, and thus the initialization voltage Vinit is applied to a node N1. Due to the initialization voltage Vinit, the gate electrode of the driving transistor T1 and the first electrode of the capacitor C1 are initiated to the initialization voltage Vinit.

[0069] Next, during a second time duration B, the initialization control signal Sn-1 is changed to the second level, the scan control signal Sn is changed to the first level, and the emission control signal En remains in the second level.

[0070] FIG. 6B illustrates an operation of the pixel circuit 410A in the second time duration B.

[0071] Since the initialization control signal Sn-1 is changed to the second level during the second time duration B, the fourth transistor T4 is turned off. Also, since the scan control signal Sn is changed to the first level, the second and third transistors T2 and T3 are turned on, and as illustrated in FIG. 6B, the data signal Dm is applied to the gate electrode of the driving transistor T1 and the first electrode of the capacitor C1 through the second transistor T2, the driving transistor T1, and the third transistor T3 connected in series in this order. Here, the driving transistor T1 is diode-connected by the third transistor T3, and thus a voltage as much as the threshold voltage V_{th} of the driving transistor T1 is applied between the first electrode and the second electrode of the third transistor T3. Accordingly, a voltage $V_{data} + V_{th}$ is applied to the node N1. In addition, in the second time duration B, the seventh transistor T7 is turned on by the scan control signal Sn. Accordingly, the reference voltage Vref is applied to a node N2. Thus, during the second time duration B, a voltage $(V_{data} + V_{th}) - V_{ref}$ is stored in the capacitor C1.

[0072] The reference voltage Vref has a voltage level at which the OLED is not turned on. Accordingly, the reference

voltage V_{ref} has a voltage level that is lower than the sum of the cathode power voltage $ELVSS$ and the threshold voltage of the OLED.

[0073] Then, in a third time duration C, the scan control signal S_n is changed to the second level and the emission control signal E_n is changed to the first level. The initialization control signal S_{n-1} remains in the second level.

[0074] FIG. 6C illustrates an operation of the pixel circuit 410A in the third time duration C.

[0075] During the third time duration C, the scan control signal S_n is changed to the second level, and thereby the second transistor T2, the third transistor T3, and the seventh transistor T7 are turned off. Also, the emission control signal E_n is changed to the first level, and thereby the fifth and sixth transistors T5 and T6 are turned on. Accordingly, the driving current I_{OLED} according to the level of the voltage stored in the capacitor C1 is generated by the driving transistor T1. The driving current I_{OLED} flows through the fifth transistor T5, the driving transistor T1, and the sixth transistor T6, and it is input to the anode of the OLED. Here, a voltage of the source electrode of the driving transistor T1 is the same as the voltage of the anode of the OLED, wherein the voltage of the anode of the OLED is $ELVSS + V_{OLED}$. Here, V_{OLED} is a voltage applied between the terminals of the OLED. A voltage of the gate electrode of the driving transistor T1 is changed, as given by Equation 3, by coupling through the capacitor C1.

$$V_g = (V_{data} + V_{th}) - V_{ref} + (ELVSS + V_{OLED}) \quad \text{Equation 3}$$

[0076] Accordingly, during the third time duration C, V_{gs} of the driving transistor T1 is given by Equation 4.

$$\begin{aligned} V_{gs} &= V_g - V_s && \text{Equation 4} \\ &= [(V_{data} + V_{th}) - V_{ref} + (ELVSS + V_{OLED})] - \\ &\quad (ELVSS + V_{OLED}) \\ &= V_{data} + V_{th} - V_{ref} \end{aligned}$$

[0077] The driving current I_{OLED} determined by V_{gs} is determined according to Equation 5.

$$\frac{I_{OLED}}{(V_{data} - V_{ref})^2} = k \frac{(V_{gs} - V_{th})^2}{(V_{data} - V_{ref})^2} = k [(V_{data} + V_{th} - V_{ref}) - V_{th}]^2 = k \quad \text{Equation 5}$$

[0078] Accordingly, the driving current I_{OLED} output from the pixel circuit 410A according to the above-described embodiment is determined regardless of the voltage of the anode of the OLED, the cathode power voltage $ELVSS$, and the threshold voltage V_{th} of the driving transistor T1. Thus, in embodiments of the present invention, the problems that the amplitude of the driving current I_{OLED} is changed due to the voltage of the anode of the OLED and thus the voltage of the data signal D_m should be increased or image quality is deteriorated can be resolved. In addition, image quality may not be deteriorated by a change of the cathode power voltage $ELVSS$.

[0079] Moreover, in embodiments of the present invention, since the data signal D_m is input through the driving transistor T1 and the third transistor T3 couples the driving transistor T1 as diode-connected, the threshold voltage V_{th} of the driving transistor T1 and the data signal D_m are stored using one capacitor C1 at the same time.

[0080] FIG. 7 is a diagram of a pixel circuit 410B according to another embodiment of the present invention.

[0081] According to one embodiment, the anode power voltage $ELVDD$ may be used as the initialization voltage

V_{init} , instead of applying the initialization voltage V_{init} separately. Thus, according to one embodiment, the second electrode of the fourth transistor T4 is connected to the anode power voltage $ELVDD$.

[0082] FIG. 8 is a diagram of a pixel circuit 410C according to another embodiment of the present invention.

[0083] According to one embodiment, an arrangement of the second transistor T2 and the third transistor T3 is changed. In one embodiment, the second electrode of the second transistor T2 is connected to the source electrode of the driving transistor T1, and the second electrode of the third transistor T3 is connected to the drain electrode of the driving transistor T1.

[0084] FIG. 9 is a diagram of a pixel circuit 410D according to another embodiment of the present invention.

[0085] According to one embodiment, the second electrode of the second transistor T2 is connected to the source electrode of the driving transistor T1, and the second electrode of the third transistor T3 is connected to the drain electrode of the driving transistor T1. Also, the anode power voltage $ELVDD$ is used as an initialization voltage instead of applying the initialization voltage V_{init} separately. Accordingly, the second electrode of the fourth transistor T4 is connected to the anode power voltage $ELVDD$.

[0086] FIG. 10 is a flowchart illustrating a method of driving an organic electroluminescent display apparatus, according to an embodiment of the present invention.

[0087] The method of driving the organic electroluminescent display apparatus, according to one embodiment of the present invention, is described with reference to the timing diagram illustrated in FIG. 5.

[0088] During the first time duration A, the gate electrode of the driving transistor T1 is initiated to the initialization voltage V_{init} in response to the initialization control signal S_{n-1} , in operation S102. According to one embodiment, the initialization voltage V_{init} may be the anode power voltage $ELVDD$.

[0089] Then, during the second time duration B, the anode of the OLED is initiated to the reference voltage V_{ref} in response to the scan control signal S_n , in operation S104. The reference voltage has a voltage level at which the OLED is not turned on, and is lower than the sum of the cathode power voltage $ELVSS$ and the threshold voltage of the OLED. Also, during the second time duration B, the capacitor C1 is charged to a level of the voltage $V_{data} + V_{th}$ by using the data signal D_m applied through the second transistor T2, the driving transistor T1, and the third transistor T3 in response to the scan control signal S_n , in operation S106. The data signal D_m is at a level of the voltage V_{data} , and the driving transistor T1 is diode-connected by the third transistor T3 so that a voltage difference between the gate electrode and the source electrode (or drain electrode) of the driving transistor T1 becomes the voltage V_{th} . Accordingly, the capacitor C1 is charged to a level of the voltage $V_{data} + V_{th}$. Operations S104 and S106 may be simultaneously or concurrently performed or sequentially performed in some embodiments.

[0090] Next, during the third time duration C, the driving current I_{OLED} is output to the anode of the OLED, in operation S108. The amplitude of the driving current I_{OLED} is determined according to the voltage level V_{data} of the data signal D_m as illustrated in FIG. 5, and the OLED emits light having luminance according to the amplitude of the driving current I_{OLED} .

[0091] According to the embodiments of the present invention, the driving current output to the organic electro-light emitting device is determined regardless of the voltage of the anode of the organic electro-light emitting device. Thus, when N-type transistors are used to realize the organic electro-light emitting device, a problem in which the luminance of light is changed by a change of the V_{gs} of the driving transistor due to a change of the voltage of the anode in the organic electro-light emitting device may be prevented. In addition, the driving current is determined regardless of the cathode driving voltage so that the luminance of light may not be affected by a change of the cathode driving voltage, and image quality may not be deteriorated.

[0092] While aspects of the present invention has been particularly shown and described with reference to exemplary embodiments thereof, it will be understood by those of ordinary skill in the art that various changes in form and details may be made therein without departing from the spirit and scope of the present invention as defined by the following claims and their equivalents.

What is claimed is:

1. A pixel circuit for driving a light emitting device comprising a first electrode and a second electrode, the pixel circuit comprising:

a driving transistor comprising a first electrode and a second electrode for outputting a driving current according to a voltage applied to a gate electrode of the driving transistor;

a second transistor for delivering a data signal to the gate electrode of the driving transistor in response to a scan control signal applied to a gate electrode of the second transistor;

a third transistor for diode-connecting the driving transistor in response to the scan control signal applied to a gate electrode of the third transistor;

a fourth transistor for applying an initialization voltage to the gate electrode of the driving transistor in response to an initialization control signal;

a fifth transistor for applying a first power voltage to the second electrode of the driving transistor in response to an emission control signal;

a sixth transistor coupled in series between the first electrode of the driving transistor and the first electrode of the light emitting device for outputting the driving current output from the driving transistor to the first electrode of the light emitting device in response to the emission control signal applied to a gate electrode of the sixth transistor;

a seventh transistor for applying a reference voltage to the first electrode of the light emitting device in response to the scan control signal; and

a capacitor comprising a first electrode and a second electrode, wherein the first electrode is coupled to the gate electrode of the driving transistor and the second electrode is coupled to the first electrode of the light emitting device,

wherein the pixel circuit is configured such that the data signal is delivered to the gate electrode of the driving transistor through the second transistor, the driving transistor, and the third transistor, and

wherein the driving transistor and the second, third, fourth, fifth, sixth, and seventh transistors are N-type transistors.

2. The pixel circuit of claim 1, wherein the light emitting device comprises an organic light-emitting diode.

3. The pixel circuit of claim 1, wherein the second transistor comprises a first electrode for receiving the data signal and a second electrode coupled to the second electrode of the driving transistor, and the third transistor comprises a first electrode coupled to the gate electrode of the driving transistor and a second electrode coupled to the first electrode of the driving transistor.

4. The pixel circuit of claim 3, wherein the initialization voltage is substantially the same as the first power voltage.

5. The pixel circuit of claim 1, wherein the second transistor comprises a first electrode coupled to the data signal and a second electrode coupled to the first electrode of the driving transistor, and the third transistor comprises a first electrode coupled to the gate electrode of the driving transistor and a second electrode coupled to the second electrode of the driving transistor.

6. The pixel circuit of claim 5, wherein the initialization voltage is the first power voltage.

7. The pixel circuit of claim 1, wherein the second electrode of the light emitting device is configured to receive a second power voltage, and the reference voltage is lower than a sum of the second power voltage and a threshold voltage of the light emitting device.

8. The pixel circuit of claim 1, wherein the initialization control signal is a scan control signal of a previous scan period.

9. The pixel circuit of claim 1, wherein the driving transistor and the second, third, fourth, fifth, sixth, and seventh transistors are N-type metal-oxide semiconductor field effect transistors.

10. The pixel circuit of claim 1, wherein the first electrode of the driving transistor is a source electrode, and the second electrode of the driving transistor is a drain electrode.

11. The pixel circuit of claim 1, wherein the pixel circuit is configured such that:

during a first time duration, when the initialization control signal is at a first level, the scan control signal and the emission control signal are at a second level;

during a second time duration, when the data signal has a valid level, the initialization control signal and the emission control signal are at the second level, and the scan control signal is at the first level; and

during a third time duration, when the initialization control signal and the scan control signal are at the second level, the emission control signal is at the first level, and

wherein the first level is a level at which the driving transistor and the second, third, fourth, fifth, sixth, and seventh transistors are turned on, and the second level is a level at which the driving transistor and the second, third, fourth, fifth, sixth, and seventh transistors are turned off.

12. An organic electroluminescent display apparatus comprising:

a pixel array comprising a plurality of pixels;

a scan driver configured to output an initialization control signal, a scan control signal, and an emission control signal to the plurality of pixels; and

a data driver configured to generate a data signal and output the data signal to the plurality of pixels,

wherein each of the plurality of pixels comprises:

an organic light-emitting diode (OLED) comprising a first electrode and a second electrode;

- a driving transistor comprising a first electrode and a second electrode for outputting a driving current according to a voltage applied to a gate electrode of the driving transistor;
 - a second transistor for delivering a data signal to the gate electrode of the driving transistor in response to a scan control signal applied to a gate electrode of the second transistor;
 - a third transistor for diode-connecting the driving transistor in response to the scan control signal applied to a gate electrode of the third transistor;
 - a fourth transistor for applying an initialization voltage to the gate electrode of the driving transistor in response to an initialization control signal;
 - a fifth transistor for applying a first power voltage to the second electrode of the driving transistor in response to an emission control signal;
 - a sixth transistor coupled in series between the first electrode of the driving transistor and the first electrode of the OLED for outputting the driving current output from the driving transistor to the first electrode of the OLED in response to the emission control signal applied to a gate electrode of the sixth transistor;
 - a seventh transistor for applying a reference voltage to the first electrode of the OLED in response to the scan control signal; and
 - a capacitor comprising a first electrode and a second electrode, wherein the first electrode is coupled to the gate electrode of the driving transistor and the second electrode is coupled to the first electrode of the OLED,
- wherein the second transistor is configured to deliver the data signal to the gate electrode of the driving transistor through the second transistor, the driving transistor, and the third transistor, and
- wherein the driving transistor and the second, third, fourth, fifth, sixth, and seventh transistors are N-type transistors.
- 13.** The apparatus of claim **12**, wherein the second transistor comprises a first electrode configured to receive the data signal and a second electrode coupled to the second electrode of the driving transistor, and the third transistor comprises a first electrode coupled to the gate electrode of the driving transistor and a second electrode coupled to the first electrode of the driving transistor.
- 14.** The apparatus of claim **12**, wherein the second transistor comprises a first electrode configured to receive the data signal and a second electrode coupled to the first electrode of the driving transistor, and the third transistor comprises a first

electrode coupled to the gate electrode of the driving transistor and a second electrode coupled to the second electrode of the driving transistor.

15. The apparatus of claim **12**, wherein the second electrode of the OLED is configured to receive a second power voltage, and the reference voltage is lower than a sum of the second power voltage and a threshold voltage of the OLED.

16. The apparatus of claim **12**, wherein the scan driver is configured such that:

during a first time duration, when the initialization control signal is at a first level, the scan control signal and the emission control signal are at a second level;

during a second time duration, when the data signal has a valid level, the initialization control signal and the emission control signal are at the second level, and the scan control signal is at the first level; and

during a third time duration, when the initialization control signal and the scan control signal are at the second level, the emission control signal is at the first level,

wherein the first level is a level at which the driving transistor and the second, third, fourth, fifth, sixth, and seventh transistors are configured to be turned on, and the second level is a level at which the driving transistor and the second, third, fourth, fifth, sixth, and seventh transistors are configured to be turned off.

17. The apparatus of claim **16**, wherein the initialization control signal is a scan control signal of a previous scan period.

18. A method of driving an organic electroluminescent display apparatus comprising a pixel array comprising a plurality of pixels, wherein each of the plurality of pixels comprises an organic light-emitting diode (OLED) and a pixel circuit comprising N-type transistors and a capacitor coupled between a gate electrode of a driving transistor and an anode of the OLED, the method comprising:

initializing the gate electrode of the driving transistor to an initialization voltage;

initializing the anode of the OLED to a reference voltage; charging the capacitor to a voltage level corresponding to a sum of a threshold voltage of the driving transistor and a data signal by diode-connecting the driving transistor and applying the data signal to the gate electrode of the driving transistor; and

outputting a driving current from the driving transistor to the anode of the OLED according to a level of a voltage charged to the capacitor.

19. The method of claim **18**, wherein a cathode of the OLED is configured to receive a second power voltage, and the reference voltage is lower than a sum of the second power voltage and a threshold voltage of the OLED.

* * * * *

专利名称(译)	像素电路，使用像素电路的有机电致发光显示装置和驱动该装置的方法		
公开(公告)号	US20110080395A1	公开(公告)日	2011-04-07
申请号	US12/766387	申请日	2010-04-23
[标]申请(专利权)人(译)	CHUNG KYUNG HOON		
申请(专利权)人(译)	CHUNG京勋		
当前申请(专利权)人(译)	CHUNG京勋		
[标]发明人	CHUNG KYUNG HOON		
发明人	CHUNG, KYUNG-HOON		
IPC分类号	G09G3/30 G06F3/038		
CPC分类号	G09G3/3233 G09G2300/043 G09G2310/0262 G09G2300/0861 G09G2300/0819		
优先权	1020090095172 2009-10-07 KR		
其他公开文献	US8823609		
外部链接	Espacenet USPTO		

摘要(译)

提供了一种包括像素电路的有机电致发光显示装置和驱动该有机电致发光显示装置的方法。本发明的实施例可以解决由于有机电光发射装置的阳极的电压的变化而改变光的亮度的问题，使得当使用N型晶体管来形成图像质量时，图像质量劣化。有机电致发光显示装置。

